

Zenox Submersible Double-Channel Pumps



- Reliable, high quality drainage pump
- Suited to dirty water and sewage applications
- Industrial, civil and domestic applications
- Ideal for home sewage or waste water disposal

Two Models Available:

BCmST 10/50-1 240 volt, 0.75 kW, Manual

BCmST 10/50-1A 240 volt, 0.75 kW, Automatic

SPECIFICATION:

- 12 metres max head
- 600 litres per minute max flow rate
- 0.75 kW, 240 volt motor
- Weight 11.9 kg
- 50 mm horizontal discharge
- 10 metre cable H07 RN-F

FEATURES:

- Robust, high quality stainless steel AISI 304 pump body
- Double mech seal separated by an oil chamber
- Stainless steel double channel type impeller
- Passage of solid bodies up to 50 mm
- Thermal overload protection
- Distinguished by quality and reliability

PUMP PERFORMANCE:

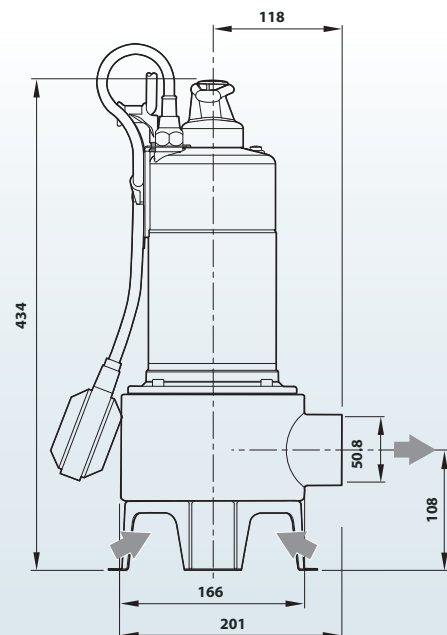
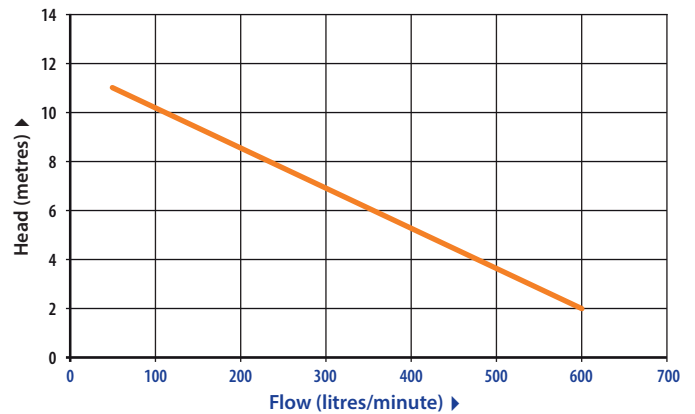

Zenox Pumps

Zenox Pumps reserves the right to change product specifications

