

Zenox Submersible Double-Channel Pumps



- High quality, high volume drainage pump
- Suited to dirty water and sewage applications
- Industrial, civil and domestic applications
- Ideal for sewage or waste water disposal

Four Models Available:

MC 20/50-1 240 volt, 1.5 kW, Manual

MC 20/50-3 415 volt, 1.5 kW, Manual

MC 30/50-1 240 volt, 2.2 kW, Manual

MC 30/50-3 415 volt, 2.2 kW, Manual

SPECIFICATION:

- 23 metres max head
- 1100 Litres per minute max flow rate
- 1.5kW/2.2 kW motor
- Weight 37.7kg/41.9kg
- 65mm vertical discharge
- 10 metre cable H07 RN-F

FEATURES:

- Robust, high quality cast iron pump body
- Stainless steel base and motor shaft
- Double-channel style impeller
- Double mechanical seal separated by an oil chamber
- Thermal overload protection
- Passage of solid bodies up to 50mm
- Minimum immersion depth of 390mm for continuous service
- Separate control box and capacitor for single-phase versions

PUMP PERFORMANCE:

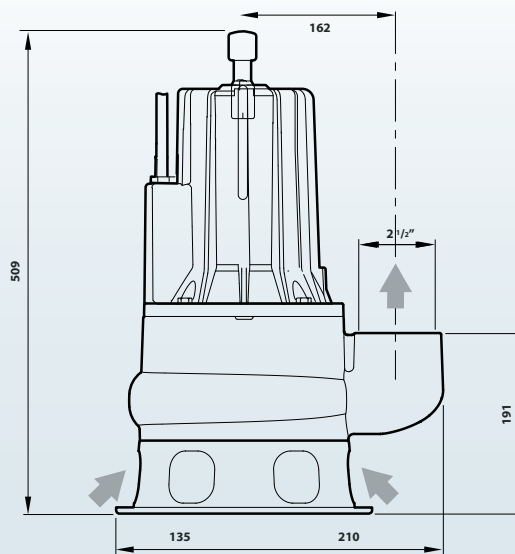
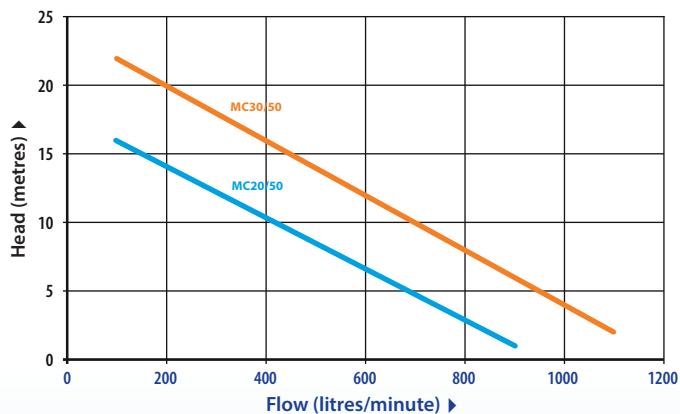

Zenox Pumps

Zenox Pumps reserves the right to change product specifications

