

## Zenox Submersible Drainage Pumps



- Robust, high quality, clear water pump
- Drainage of domestic water or rainwater
- Emptying of sumps and tanks

### Three Models Available:

**SSS-037-1** 240 volt, 0.37 kW, Manual

**SSS-037-1A** 240 volt, 0.37 kW, Automatic

**SSS-055-1A** 240 volt, 0.55 kW, Automatic

### SPECIFICATION:

- 10/12 metres max head
- 220 litres per minute max flow rate
- 0.37/0.55 kW submersible asynchronous 240 volt motor for continuous duty
- Strainer inlet
- 32 mm outlet
- Weight 5.8/7.2 kg
- 10 metre cable H07 RN-F

### FEATURES:

- Stainless steel shaft
- Stainless steel AISI 304 pump body

- Stainless steel impeller
- Mech seal, ceramic – graphite – NBR, plus inner lip seal in oil barrier chamber
- Stainless steel motor support
- Thermal overload protection
- Robust construction, very reliable and will withstand liquid temperatures up to 60°C
- Will withstand 90°C liquid temperatures in 3 minute intervals

### PUMP PERFORMANCE:

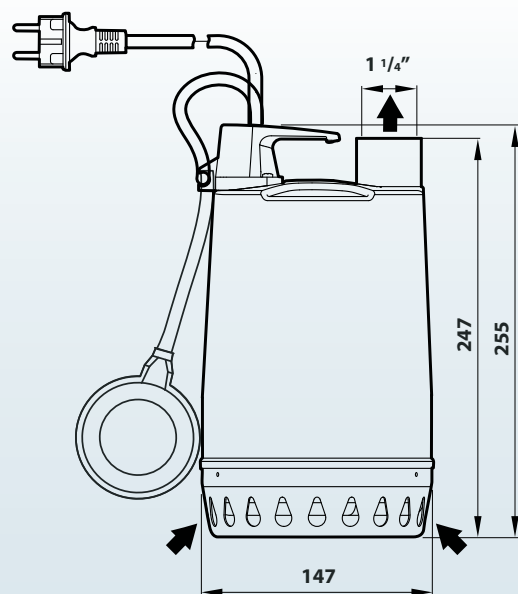
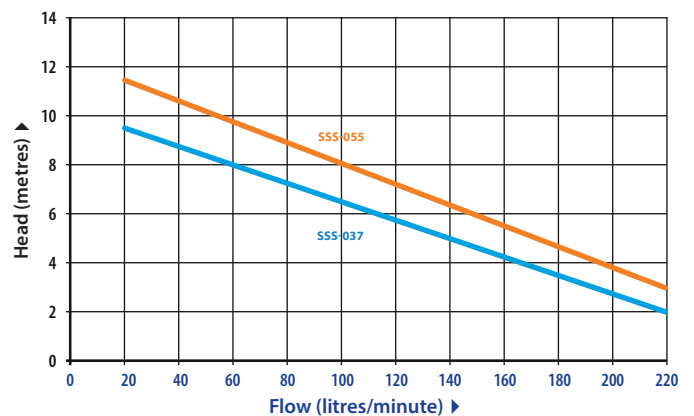

Zenox Pumps

Zenox Pumps reserves the right to change product specifications

